

## CARRETTINO 250

- Vano aerato
- Ventilated compartment
- Logement aéré
- Belüfteter Raum
- Alojamiento ventilado



+4° C

Colori standard  
Standard colors



COD. 04 COD. 05 COD. 07

Colori optional  
Optional colors



RAL COD. 07T

	°C	mm. (LxPxH)	Li.	<b>DI SERIE</b>	Watt	% U.R.	DEFROST			Kg.			
Carrettino 250	+4/+10	1339x560x1078	240	n° 2 mm. 700x380	500	60-70		230v/1/50Hz		R134a	93	-	di serie

Dati di collaudo • Test details • Détails d'essai • Prüfungsergebnisse • Datos de ensayo • MAX = (30°C - % U.R. 55)



Prezzi vedi LISTINO a pagina 94  
See PRICE LIST on page 94

CARRELLINO 3

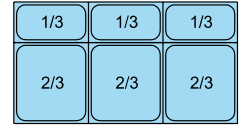
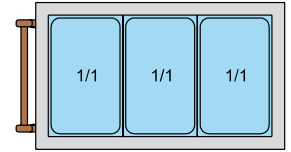
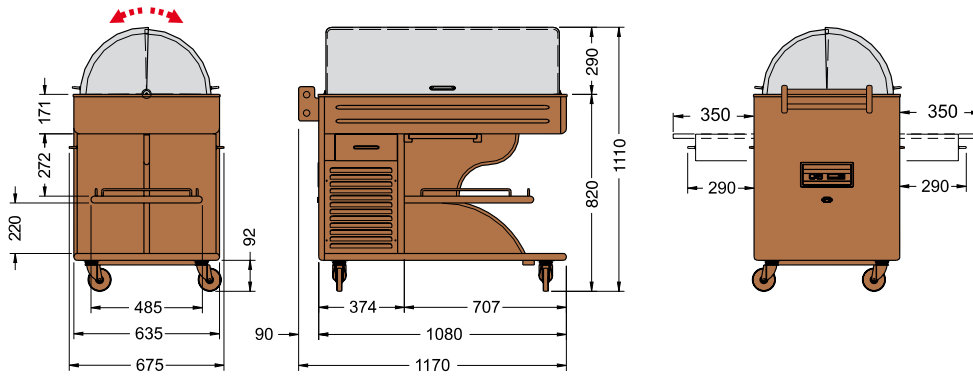

CARRELLINO 3 (Pasticceria)

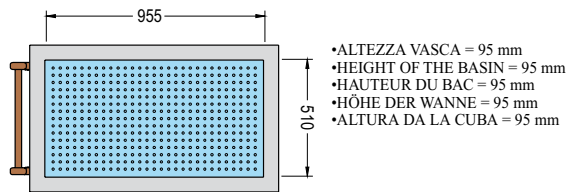

- ALTEZZA VASCA = 95 mm
- HEIGHT OF THE BASIN = 95 mm
- HAUTEUR DU BAC = 95 mm
- HÖHE DER WANNE = 95 mm
- ALTURA DA LA CUBA = 95 mm

- LE VASCHE SONO FORNITE A RICHIESTA.
- BASINS ARE AVAILABLE ON REQUEST.
- LES BACS SONT FOURNIS SUR DEMANDE.
- DIE SCHALEN WERDEN AUF WUNSCH GELIEFERT.
- LAS CUBETAS SE ENTREGAN BAJO DEMANDA.

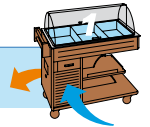

CARRETTINO 250

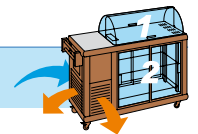
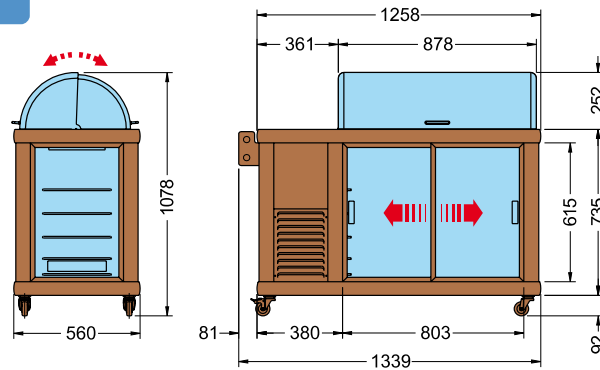

CARRELLINO EIS

